

PNI White Paper

Tilt-Induced Heading Error in a 2-Axis Compass

Andrew Leuzinger

July 2010

This white paper provides a brief overview of how a 2-axis compass works and an explanation of Earth's magnetic field inclination (or dip angle), and follows this with a discussion of how the inclination can lead to heading errors when using a 2-axis compass.

2-AXIS COMPASS OVERVIEW

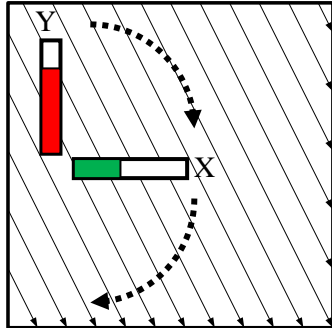

Figure 1: 2-axis Compass in Earth's Magnetic Field

Consider a compass comprised of 2 magnetic sensors (X and Y) which are mounted orthogonally to each other and in a horizontal plane (i.e. a 2-axis compass). Each sensor measures the strength (either positive or negative) of the magnetic field which is parallel to its orientation. This is depicted in Figure 1, where the compass is superimposed over the magnetic field. The length of the bar represents the strength of the magnetic field and the color (red or green) represents whether the field is positive or negative.

Figure 2 shows that when the X sensor is pointing directly towards the magnetic north pole, the X sensor provides a maximum strength signal and the Y sensor provides no signal at all. This will be relevant later in the example we'll use to discuss 2-axis heading error.

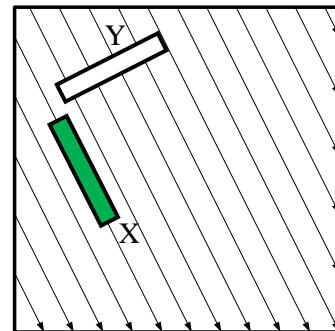

Figure 2: 2-axis Compass Aligned to Magnetic North

INCLINATION ANGLE OVERVIEW

In the previous discussion, we depicted Earth's magnetic field as existing in a horizontal plane, but this is a simplification since Earth's field is a vector which can be resolved as having horizontal components (X and Y axes) and a vertical component (Z axis). The angle between Earth's magnetic field vector and the ground is referred to as the *inclination* or *dip angle*. An inclination of 0° means the magnetic field is horizontal to the surface of the Earth (i.e. at the magnetic equator) while an inclination angle of 90° occurs at the magnetic poles. Note that heading corresponds only to the horizontal components but, as we'll see in the next section, the vertical component can lead to errors.

The inclination angle varies with location and very gradually varies over time. Table 1 provides inclination angles for a variety of cities around the world, while Figure 3 provides a world map with inclination lines plotted at 2° increments. The map, magnetic field calculator (including inclination), and more can be found at <http://www.ngdc.noaa.gov/geomag/geomag.shtml>.

Table 1: Dip angles (Inclination) for Various Cities (May 2010)

City	Inclination		City	Inclination
Anchorage USA	74.2		Olso NOR	72.7
San Francisco USA	61.3		Berlin DEU	67.8
Houston USA	59.1		Johannesburg ZAF	-63.2
Boston USA	67.9		Tel Aviv ISR	47.9
Edmonton CAN	75.5		Dubai UAE	39.2
Toronto CAN	70.4		Mumbai IND	26.9
Lima PER	0.4		Singapore SGP	-15.4
Rio de Janeiro BRA	-37.3		Beijing CHN	58.5
Nuuk (Godthab) GRL	78.6		Tokyo JPN	49.3
London GBR	66.5		Sydney AUS	-64.3

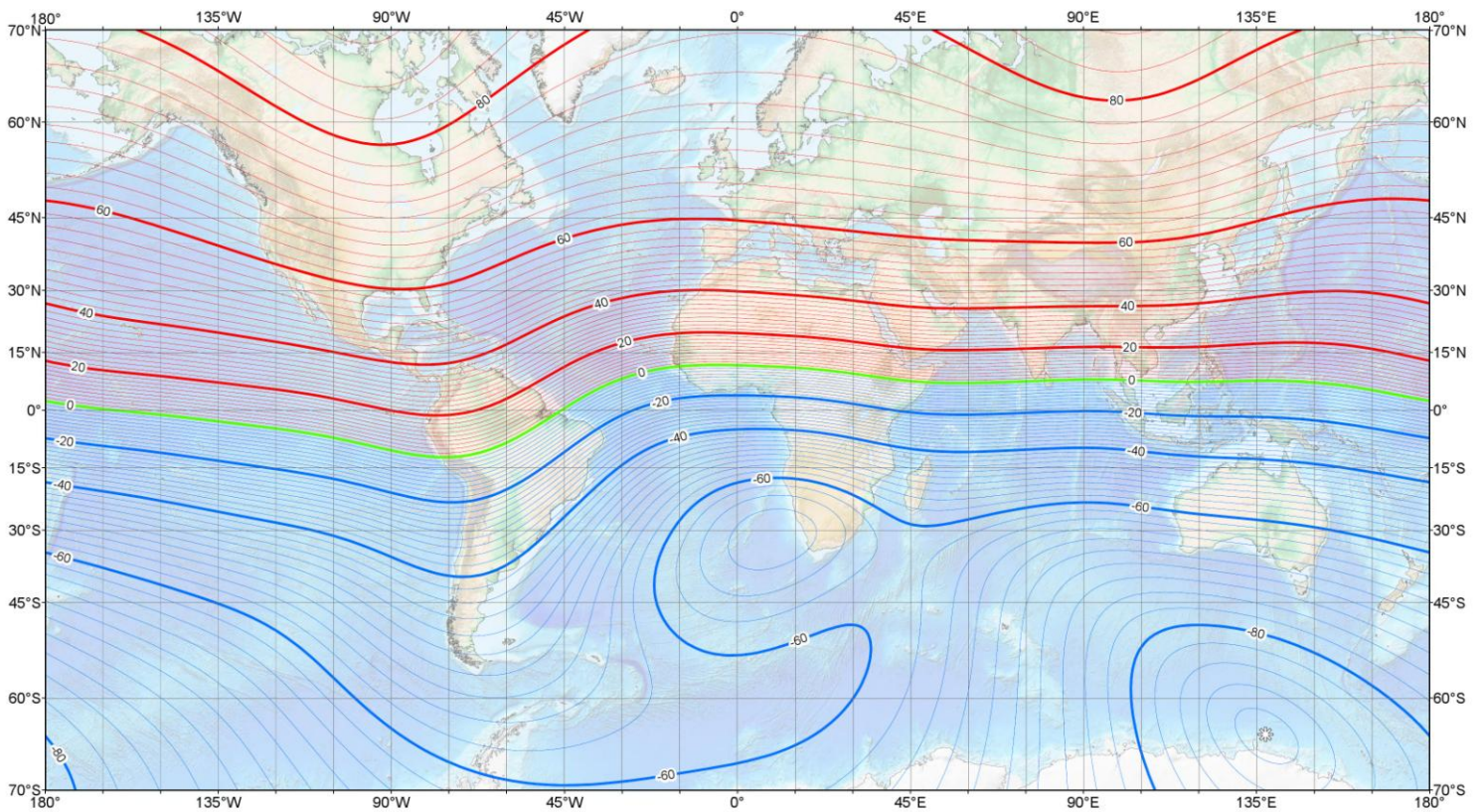

Figure 3: World Magnetic Model – Inclination (2010)

2-AXIS COMPASS HEADING ERROR

As can be seen in Table 1 and Figure 3, the inclination angle or vertical component of the magnetic field is significant in many parts of the world. And this can cause problems when making heading measurements with a 2-axis compass.

Let's take the case of a compass mounted in a vehicle that is heading due magnetic north, and that is travelling with no pitch or tilt. In this case, a 2-axis compass would look like that depicted in Figure 2, with a maximum reading along the X sensor and no reading at all along the Y sensor. Let's also assume the compass is in an area where the inclination angle is nominally 45°. This case is shown below in Figure 4.

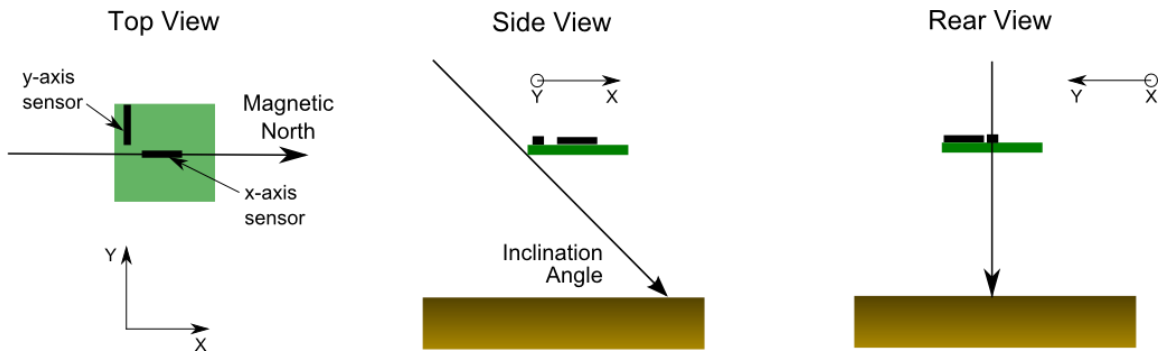

Figure 4: North heading compass with no tilt and nominally 45° inclination angle

Now if the compass is tilted around the X axis, the vertical component of the magnetic field is detected by the Y-axis sensor. This is depicted in Figure 5, where the final frame shows that the compass heading reading no longer indicates due magnetic north, even though the compass and vehicle are actually still heading in that direction.

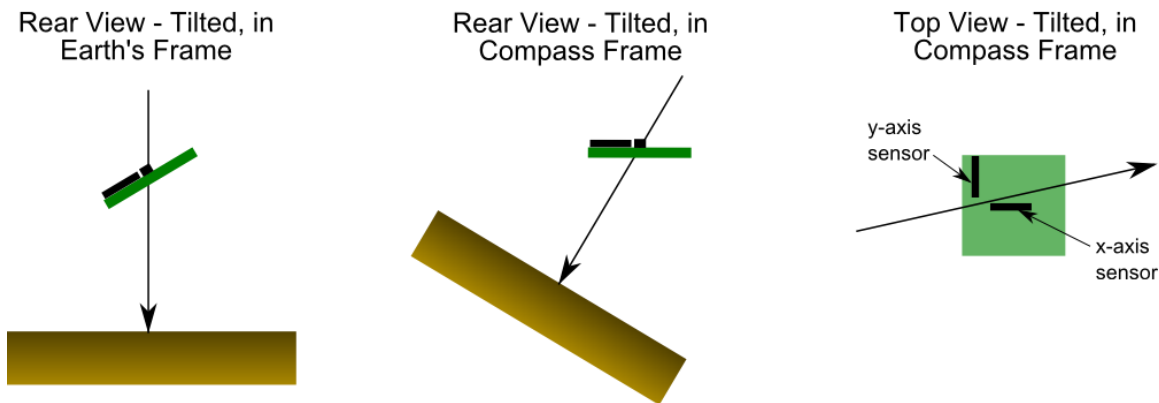

Figure 5: North heading compass with some tilt & showing heading error

The amount of heading error for the above case is given by Equation 1 below.

$$\text{Equation 1: Heading Error} = \arctan\left[\frac{\sin(\text{tilt}) \cdot \sin(\text{inclination})}{\cos(\text{inclination})} \right]$$

For inclination angles of around 60° (similar to those found in North America and Europe), this equation shows that every 1° of tilt introduces about 2° of heading error.

As can be seen, the inclination angle contributes more to the heading error than the tilt angle, since it occurs in both the numerator and denominator of the equation.

Note that 2-axis compass heading readings are sensitive to tilt around the axis of the magnetic field vector. Consequently, if a vehicle was heading magnetic east, there would be no heading error when the vehicle tilted, as the tilt of the vehicle would be orthogonal to the axis of the magnetic field. If the vehicle pitched, though, this would have the same affect as tilting the compass when heading north.

Also, Equation 1 assumes there is no pitch to the compass (rotation about the Y axis). If there is pitch, this is equivalent to either increasing or decreasing the inclination angle. For instance, if the compass were to pitch up by 15° , this would be equivalent to the increasing the inclination from nominally 45° (as shown in Figure 4) to 60° .

3-AXIS COMPASSING TO ALLEVIATE HEADING ERROR

Since the mathematics of 2-axis compassing heading error are well understood, it is possible to correct for errors introduced by tilt. This is done by adding a 3-axis accelerometer and a 3rd magnetic sensor in the Z axis. The accelerometer measures force, specifically gravitational force, and by having a 3-axis accelerometer it is possible to determine which way is “down”. By understanding the direction of the gravitation vector, it is possible to understand the amount of tilt the compass is experiencing. The 3rd axis magnetic sensor also provides tilt information, as well as allowing for high resolution measurements when the compass is tilted.

PNI pioneered tilt-compensated compassing with their TCM product line and continues to offer the most accurate compasses available for real-world applications. For information on PNI’s compassing modules, go to www.pnicorp.com.